

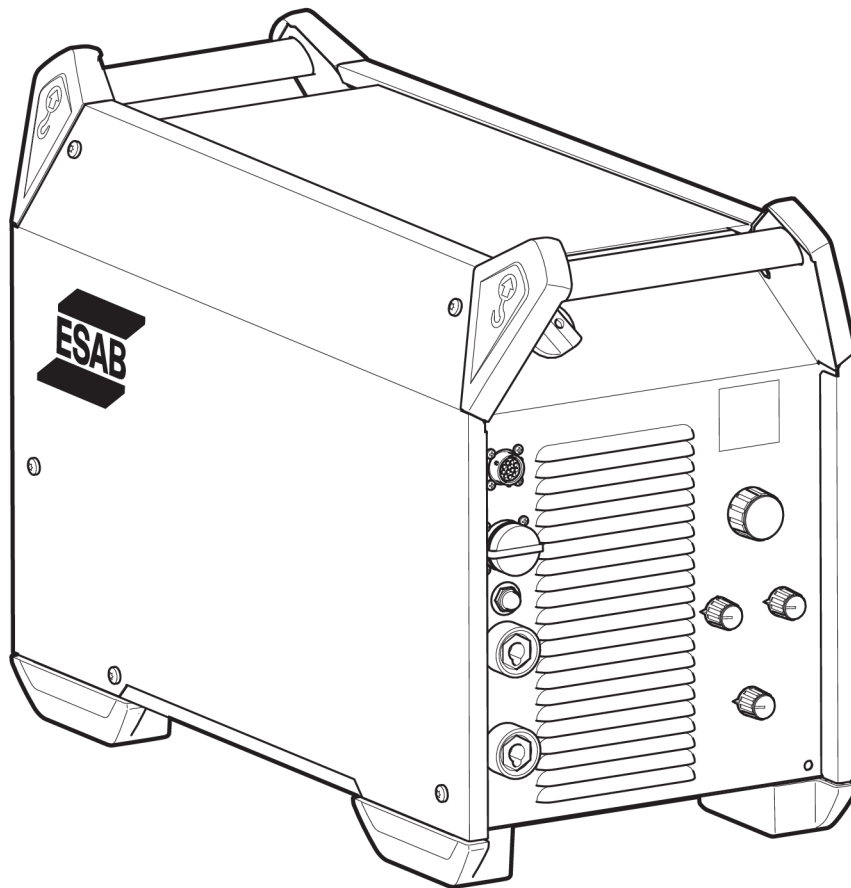

Warrior™ 400i CC/CV

Warrior™ 500i CC/CV

Warrior™ 500i ECHO CC/CV



Spare parts list

Ordering no.	Product	Note
0465 350 880	Warrior™ 500i CC/CV, 380 - 460 V	
0465 350 881	Warrior™ 500i CC/CV, 460 V USA	
0465 350 882	Warrior™ 400i CC/CV, 380 - 460 V	
0465 350 887	Warrior™ 500i CC/CV, 575 V Canada	
0448 550 881	Warrior™ 500i ECHO CC/CV, 380-575 V CSA	Valid for OP438YY-XXXXXX
0448 550 882	Warrior™ 500i ECHO CC/CV, 380-460 V SAM	Valid for OP441YY-XXXXXX

Spare parts are to be ordered through the nearest ESAB agency. Kindly indicate type of unit, serial number, denominations and ordering numbers according to the spare parts list.

Maintenance and repair work should be performed by an experienced person, and electrical work only by a trained electrician. Use only recommended spare parts.

SPARE PARTS 4

A Housing module..... 4

B Power module 6

C User interface 10

D Mains module 10

E IPS module..... 10

F Control module..... 12

G Secondary connection 12

H Primary inverter 14

J Secondary rectifier..... 14

K Warrior™ 400i / 500i upgrade kit for AVS ECHO 16

Warrior™ 500i ECHO CC/CV (in-built assembly - 0448 550 881, 0448 550 882)

SPARE PARTS

A Housing module

Item	Qty	Ordering no.	Denomination	Notes	Component designation
A1	1	0465 375 880	Side panel, left		
A2	1	0465 375 881	Side panel, right		
A3	2	0465 293 002	Handle corner part		
A4	2	0465 293 001	Handle corner part		
A5	1	0465 196 001	Top panel		
A6	4	0465 415 001	Foot		
A7	1	0465 331 001	Rubber mat		
A9	4		Washer BRB	12×6.4×1.5	
A10	4		Screw IN6	M6×30	
A11	1	0194 069 003	Grommet	D 37 mm	
A12	18		Screw MRT	M16×16 black	
A14	3		Screw RX-PT	8 -16×20	
A15	4		Screw RTS	ST3.5, 5×9,5	
A16	2		Screw REMFORM TORX	5×16	
A17	2		Screw MRT	M3×8	

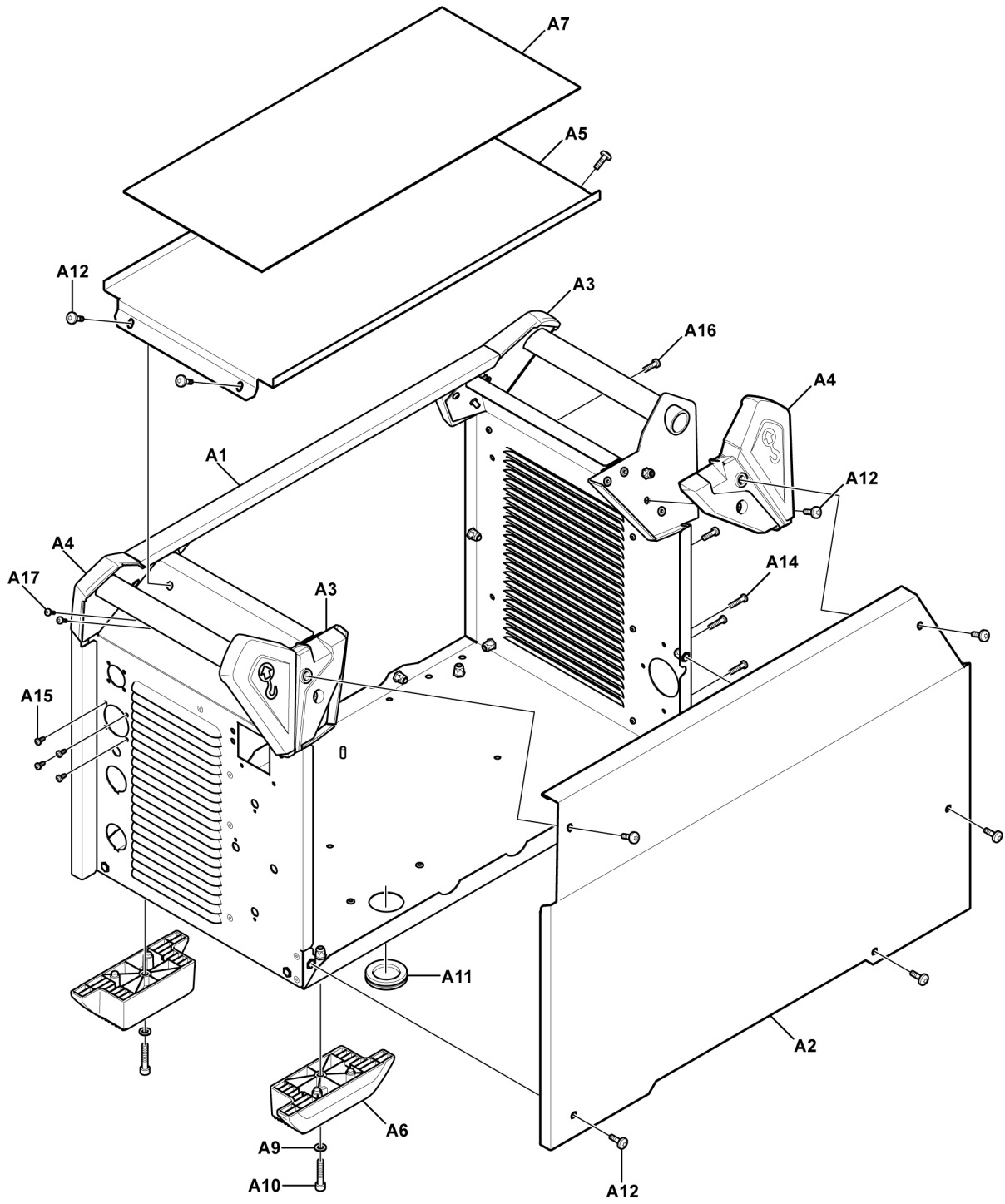

B Power module

Item	Qty	Ordering no.	Denomination	Notes	Component designation
B1	1	0465 302 880	Transformer, complete	Warrior 400i and 500i, 380-460V	15T1
B1	1	0465 302 881	Transformer, complete	Warrior 500i, 380-575V	15T1
B2	1	0465 311 880	Inductor, complete		15L1
B3	1	0440 003 886	PCBA Power board	Same circuit board for all units	15AP1
B4	1	0465 287 880	Secondary rectifier harness		
B5	1	0465 344 001	Fan		15EV1
B6	8	0455 569 006	Ferrite ring core	Core torodial amorphous	15L2 to 15L9
B7	1	0465 487 001	Air baffle fan		
B8	1	0465 367 880	Louver front IP, Assembly		
B9	1	0458 063 001	Current sensor	500 A	15CS1
B11	1	0465 332 001	Fan louver bracket		
B12	19		Screw MRT	M5×8, DIN7985	
B13	5		Screw MRT	M4×8, DIN7985	
B14	4		Screw MRT	M5×12, DiN7985	
B15	4		Screw		
B16	6		Screw MRT COMBI	M6×16	
B17	2		Screw M6S	M8×25	
B18	1		Screw Remform TORX	M5×16	
B19	5		Screw RTS	ST4, 2×13	
B20	4		Screw RTS	ST4, 8×13	
B21	1		Nut	M8-8-A2K	
B22	1		Nut	M5-8-A2K	
B23	4		Washer BRB Steel	D10/5, 3×1	
B24	4		Washer BRB	12×6, 4×1.5	
B25	2		Washer BRB	16/8, 4×1.5	
B26	4		Spring washer FBH	D11.8/6	
B27	1		Locking washer AZ	D10/5.3	
B28	4		Cup spring 16	16×8.2 T=0.9	
B29	6		Spacer	28.6 mm	
B30	7		Spacer screw	M4×15	
B31	13		Screw MRT COMBI	M5×10	
B32	1	0440 027 880	PCBA capacitor board		15AP2
B33	1	0465 450 001	Cap board insulation		

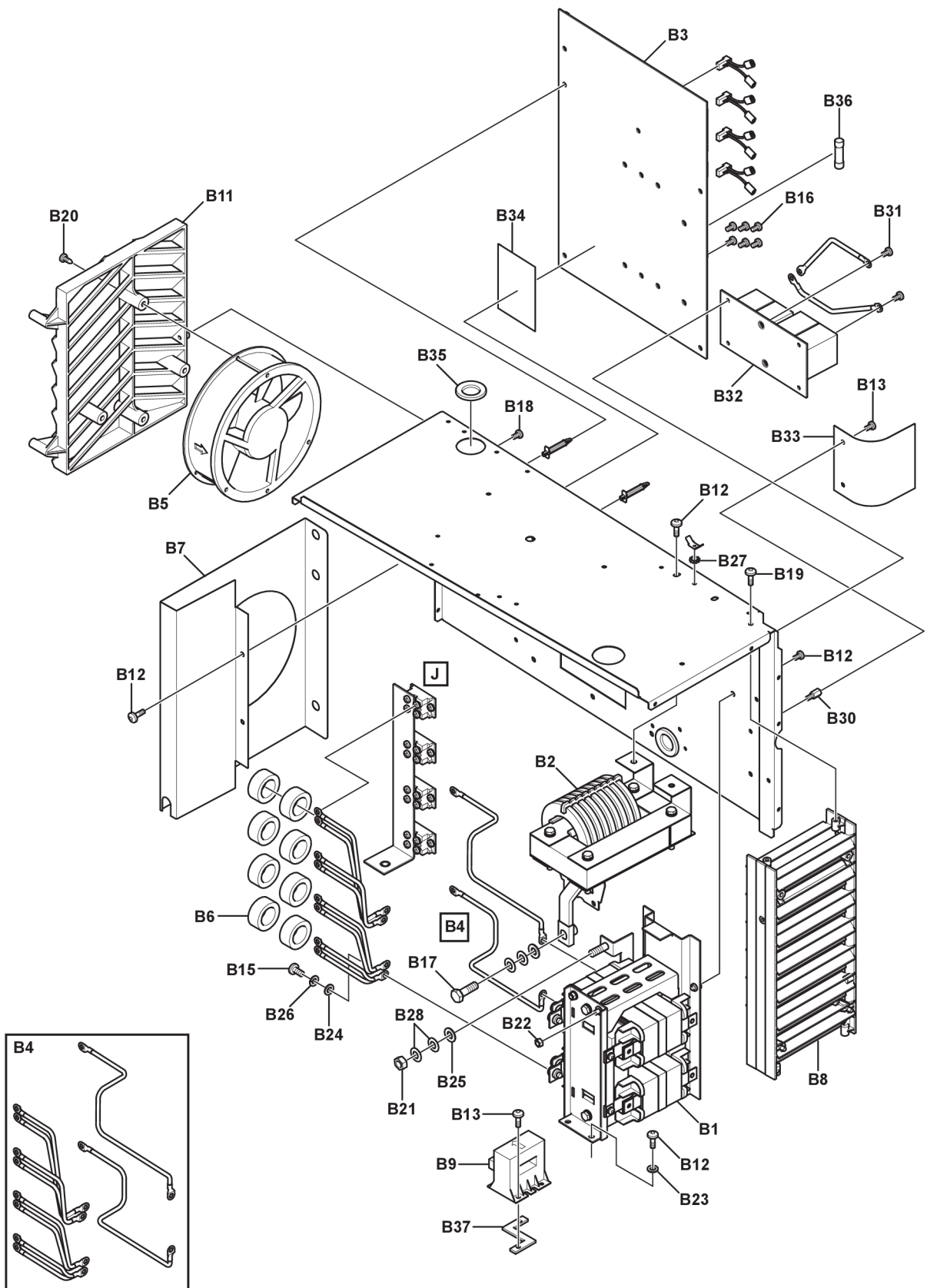

SPARE PARTS

Item	Qty	Ordering no.	Denomination	Notes	Component designation
B34	1	0465 496 001	Thermal protection insulation		
B35	4	0194 069 002	Grommet	D 28 mm	
B36	1	0194 399 120	Fuse	600 V, 5 A S3	
B37	1	0465 588 001	Current sensor distance		

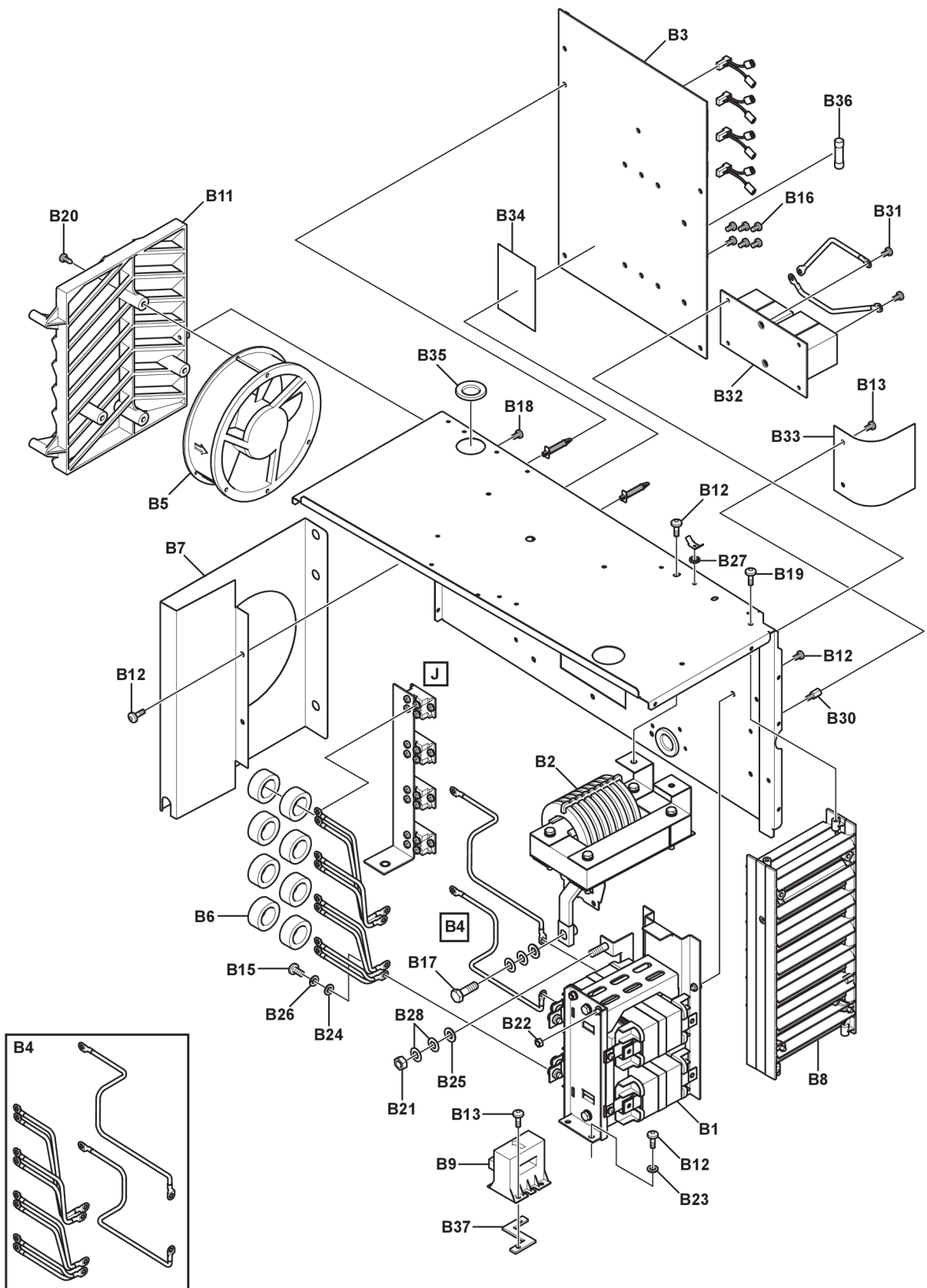

C User interface

Item	Qty	Ordering no.	Denomination	Notes	Component designation
C1	1	0440 008 880	PCBA display board		1AP1
C2	1	0465 326 880	User interface harness PS1		
C3	1	0465 327 880	Encoder assembly		1G1
C4	1	0321 475 893	Knob	D36-1/4"	
C5	3		Spacer screw	M4×12	
C6	3	0321 475 881	Knob		
C7	1	0465 414 001	Front decal	W 500i	
C7	1	0465 413 001	Front decal	W 400i	
C8	3		Nut M6M 4		
C9	2		Locking washer	10, 5×18	
C10	3		Spacer screw	M4×5	

D Mains module

Item	Qty	Ordering no.	Denomination	Notes	Component designation
D1	1	0440 018 880	PCBA mains filter PS1		2AP1
D2	1	0465 354 001	Main switch		2QF1
D3	1	0465 354 002	Knob for main switch		
D4	1	0469 950 880	Strain relief		
D5	1		Nut M6M	M6	
D6	1		Washer lock	6.4×11 S	
D8	1		Spacer screw	M5×18	
D9	1		Screw MRT	DIN7985 M4×8	
D10	2		Washer	Cable MSG KB6.5	
D11	2		Screw	M6×70	
D12	1	0465 354 003	Main switch gasket		

E IPS module

Item	Qty	Ordering no.	Denomination	Notes	Component designation
E1	1	0465 323 001	Auxiliary transformer	W 400i & W 500i, 380-460 V	2T1
E1	1	0465 323 002	Auxiliary transformer	W 500i, 380-575 V	2T1
E2	1		Screw M6S	M8×65	

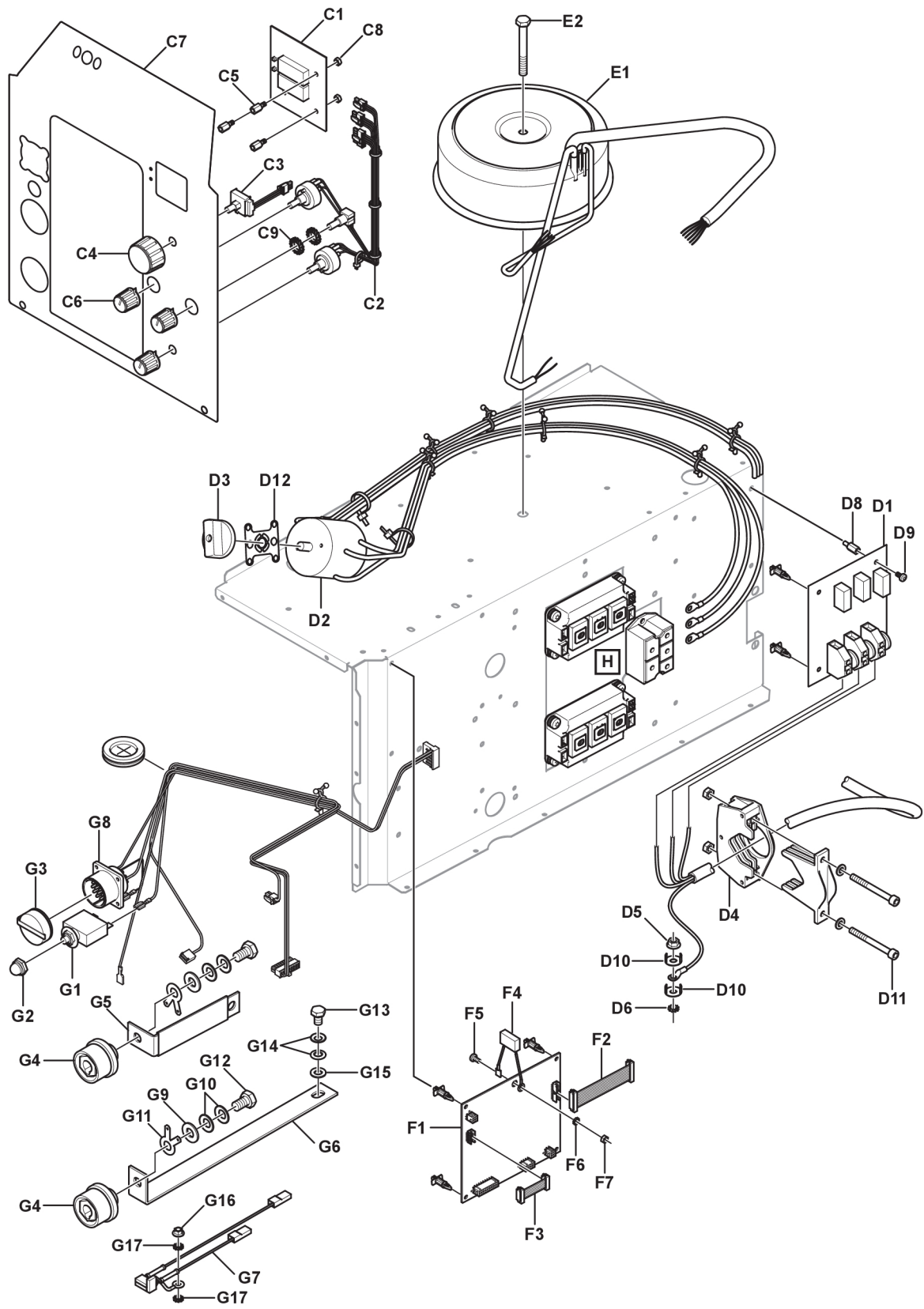

F Control module

Item	Qty	Ordering no.	Denomination	Notes	Component designation
F1	1	0487 969 880	PC board control 400 A		20AP1
F1	1	0487 969 881	PC board control 500 A		20AP1
F2	1	0465 329 880	Flat cable w connector 20-pol		7001
F3	1	0465 349 880	Flat cable w connector 12-pol		7002
F4	1	0467 911 888	Capacitor		20C1
F5	1		Screw MRT	DIN7985 M4×8	
F6	1		Washer lock AZ	4.3×8 ST	
F7	1		Nut M6M 4		

G Secondary connection

Item	Qty	Ordering no.	Denomination	Notes	Component designation
G1	1	0193 586 102	Automatic fuse	10 A	15FU1
G2	1	0455 376 001	Protection cap		
G3	1	0465 514 007	Protection cap		
G4	2	0160 362 881	Machine contact OKC	50 mm ²	XS1, XS2
G5	1	0465 309 001	Rail, inductor to OKC		
G6	1	0465 307 001	Rail, sec diodes to OKC		
G7	1	0463 082 880	Capacitor, complete		
G8	1	0538 500 204	Sleeve contact		
G9	2		Washer BRB		
G10	4		Cup spring	20/10.2 T=1.1	
G11	2		Flat pin connector	M10 6.3×0.8	
G12	2		Screw M6S	M10×16	
G13	1		Screw M6S	M8×12	
G14	2		Cup spring	16×8.2 T=0.9	
G15	1		Washer BRB	16/8, 4×1.5	
G16	1		Nut M6MF-8	FZB M5	
G17	2		Washer lock	D10/5.3	

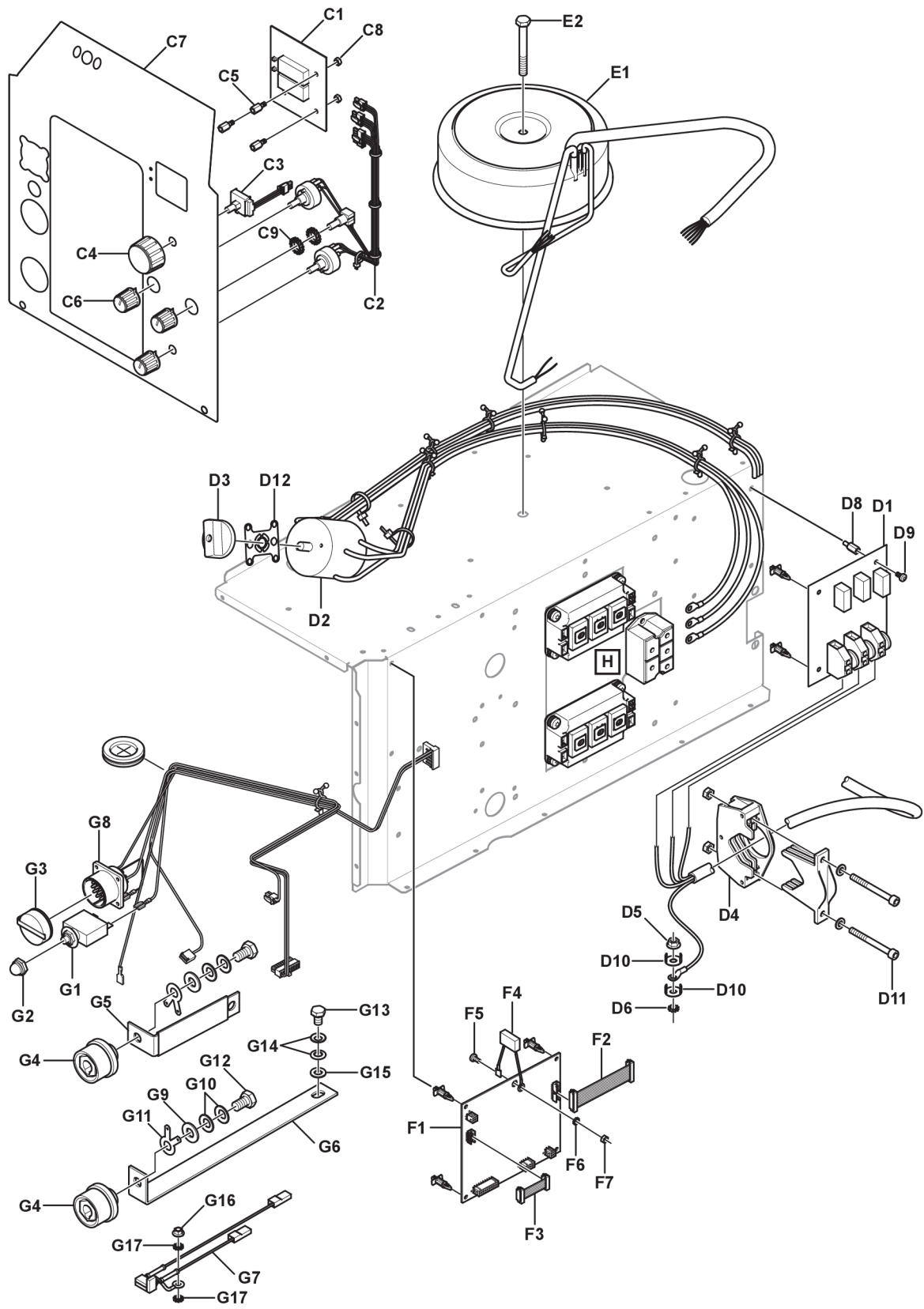

H Primary inverter

Item	Qty	Ordering no.	Denomination	Notes	Component designation
H1	1	0464 503 880	IGBT module set	Includes 2 IGBT modules, 1 thermal protection insulation, 1 thermal compound and 8 screws M6×20	15PM1, 15PM2
H2	1	0467 864 006	Thermostat		15ST2
H3	1	0464 504 880	Rectifier set	Includes 1 rectifier bridge, 1 thermal compound and 2 screws M5×12	15BR1
H4	8		Screw MRT COMBI	M6×20	
H5	2		Screw MRT COMBI	M5×12	

J Secondary rectifier

Item	Qty	Ordering no.	Denomination	Notes	Component designation
J1	1	0464 505 880	Diode set	Includes 4 diodes, 1 thermal compound, 8 screws M4×8 and 8 cup springs D8/4×0.4	15PM3 to 15PM6
J2	1	0467 864 006	Thermostat		15ST3
J3	1	0465 308 001	Rail, sec diodes		
J4	2		Washer lock	D10/5.3	
J5	1		Nut M6MF-8	M5	
J6	1		Screw MRT	DIN7985 M5×8	
J7	8		Screw MRT	DIN7985 M4×8	
J8	8		Cup spring	D8/4×0.4	

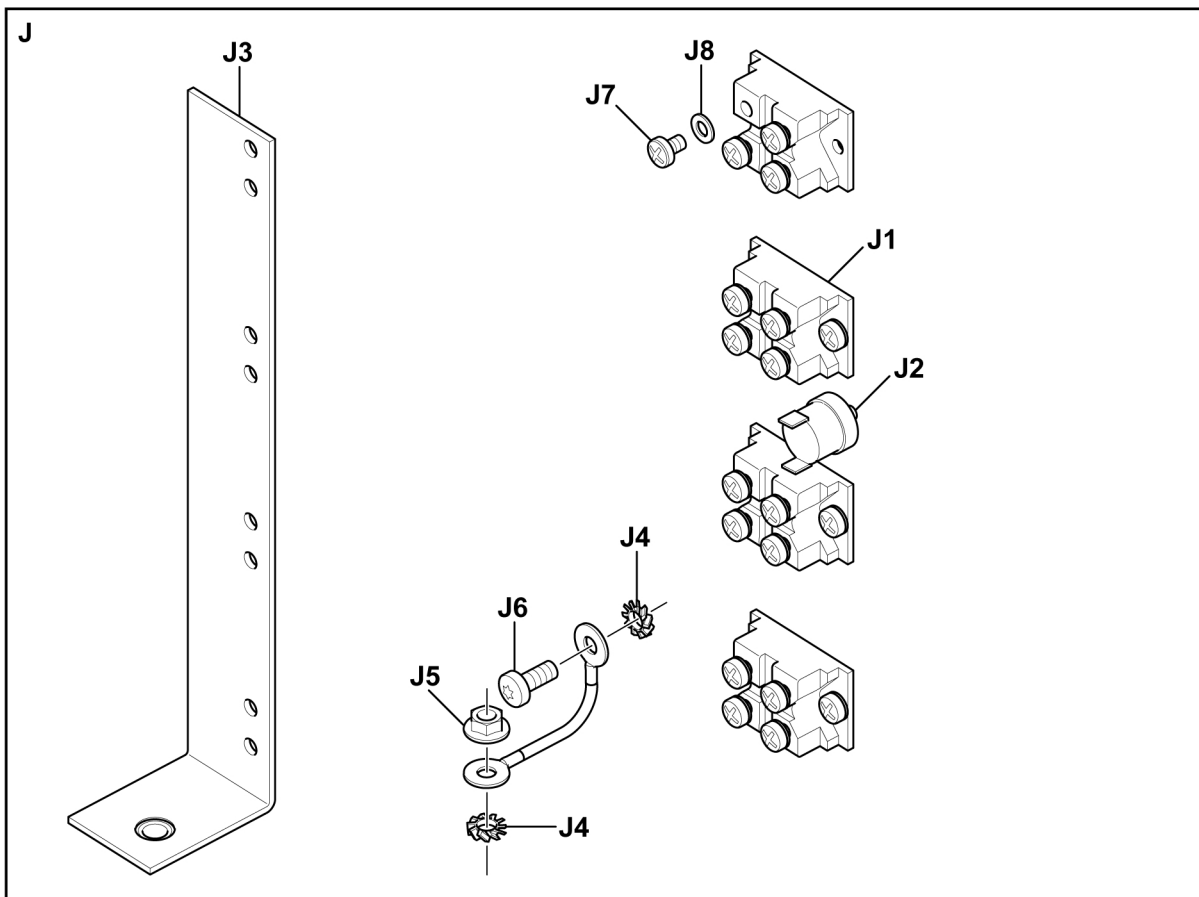
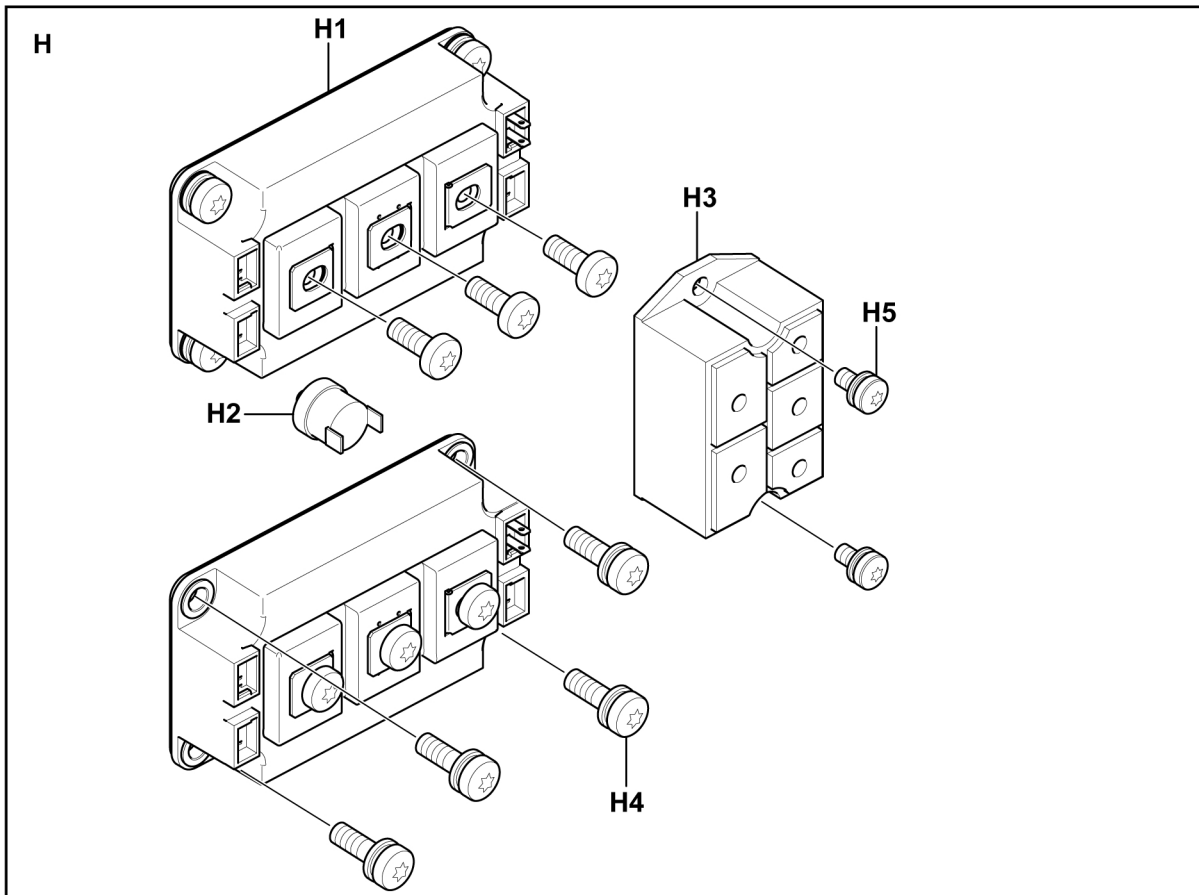

**K Warrior™ 400i / 500i upgrade kit for AVS ECHO
Warrior™ 500i ECHO CC/CV (in-built assembly - 0448 550 881,
0448 550 882)**

Item	Qty	Ordering no.	Denomination	Notes	Component designation
K1	1	A000 100 260	Transformer complete	Includes top mounting bracket, see item 101.	
K2	1	0448 104 880	Bottom mounting bracket assembly	See item 101.	
K3	1	A000 100 262	Transceiver PCBA nomex sheet	See item 101.	
K4	1	0440 724 880	Transceiver board	See item 101.	20AP2
K5	1	0448 106 880	OKC terminal harness	Connection between CN6 control board (20AP1) to XS1(+) and XS2(-) OKC terminals, see item 101.	
K6	1	0448 108 880	Power board harness	Connection between CN2 power board (15AP1) to CN4 transceiver board (20AP2), see item 101.	
K7	1	0448 110 880	Control board harness	Connection between CN10 and CN25 power board (15AP1) to CN1 transceiver board (20AP2), see item 101.	
K8	4	0394 516 017	Spacer, M4×8	See item 101.	
K9	4		Screw, M4×6	See item 101.	
K10	1		Installation guide	Except 0448 550 881, 0448 550 882 see item 101.	
K11	1		Label with product information	Stick the label as per service manual, except 0448 550 881, 0448 550 882 see item 101.	
K12	1	A000 100 658	Software upgrade kit	Include software upgrade instruction, see item 101.	
Item	Qty	Ordering no.	Denomination	Notes	
101	1	0448 101 880	Warrior™ 400i / 500i upgrade kit for AVS ECHO	Including item K1 to K12 (For Warrior™ 500i ECHO CC/CV, the items mentioned above will be as an in-built assembly).	

* To install Warrior™ 400i / 500i upgrade kit, refer Warrior™ 400i / 500i service manual (0740 800 221).

*In the Warrior™ 500i ECHO CC/CV, the items included in the Warrior™ upgrade kit are integrated into the in-built assembly.

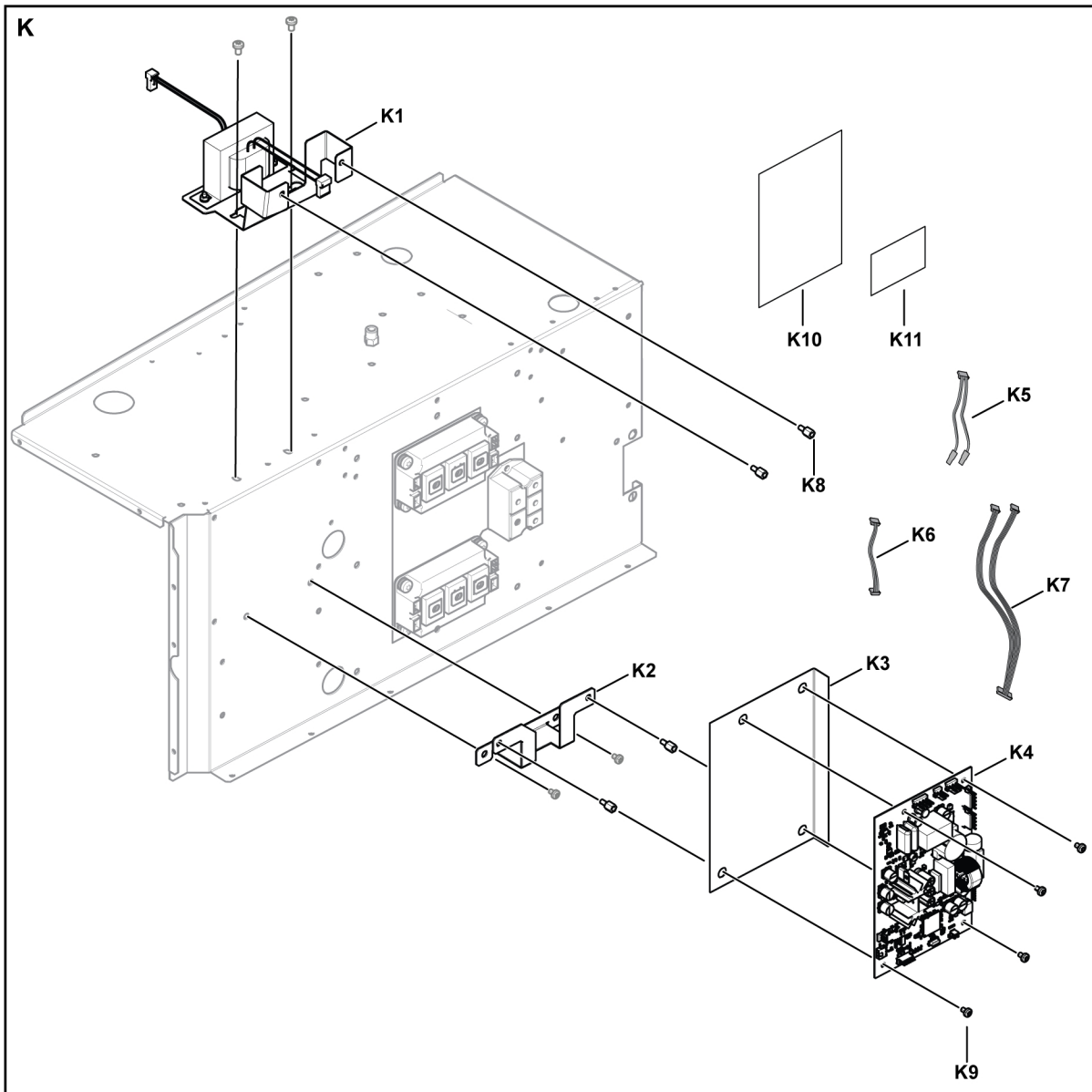



A WORLD OF PRODUCTS AND SOLUTIONS.



For contact information visit esab.com

ESAB Corporation, 2800 Airport Road Denton, TX 76207, USA, Phone +1 800 378 8123

manuals.esab.com

